

SPINS
SOUTHERN PACIFIC INDUSTRIAL
NUMBERING SYSTEM

Spins is a standard method of identifying industries and switching zones, tracks and consignee loading and unloading spots. By giving zones, tracks and spots certain designated numbers, we are able to print switch lists with the exact location to which a customer's car is to be spotted.

A spins number contains up to six digits. The first two digits indicate the zone to which the car is destined, the next two digits indicate the track number within the zone, the last two digits are the actual spot or coded spot.

EXAMPLE: Spins coded 473701 means that the car is for Zone 47, Track 37, Spot 01 on that track.

Zone and Track number appear on switch targets. Spot signs are placed where customers normally load or unload their cars.

Spot signs are 6" x 6" green metal signs with 4" white reflectorized numbers. These signs are placed at center of a car spot for spotting if possible from either side of car.

RW Daily 548 62 5897

FOR YOUR SAFETY!

Be Alert to the Principal Sources
of Accidents!



970.190-195

**To Avoid A Painful Accident
Always Grip Air Hose Firmly
Before Opening Angle Cock!**

COYOTE TO WATSONVILLE JCT.

HOLLISTER BR.

SANTA CRUZ BR.

DAVENPORT BR.

MONTEREY BR.

SALINAS SUBDIVISION

**WATSONVILLE
ZONES**

**SALINAS
ZONES**

11 THRU 18



FOR YOUR SAFETY!

Be Alert to the Principal Sources
of Accidents!

R W DANLEY 548 62 5897

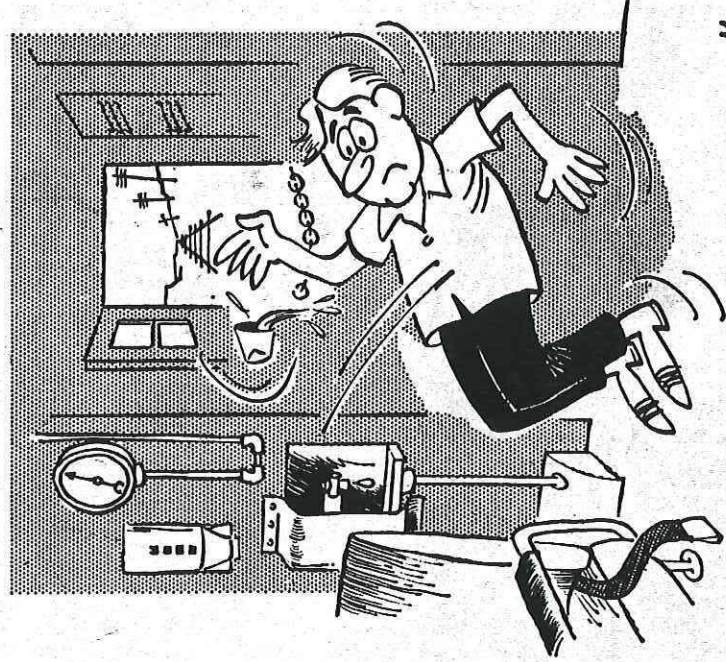

Watch Out for Slack Action!

Don't Be A Fall Guy



Procedures listed below must be complied with in filling out the printed lists.

1. Cars properly spotted or placed opposite each show the letter "S" and write time placed to the nearest hour.
2. Cars not spotted according to list, opposite each show "00" for off spot code, actual location-track and or where car was placed and reason why car could not be spotted.
3. Cars pulled from the industry opposite each show the letter "P" write the time to the nearest hour, if car is left in the industrial area, show track and time.
4. Respotted or switched car, opposite each show the letter "R", new location (Zone, Track and Spot) of car and write time to closest hour.
5. Write job number, date, name and on duty time on all lists in space provided.
6. Any cars not shown on the printed lists and are pulled from an industry, write car initial and number as well as track pulled from on the Zone-Pull list.
7. Return finished printed spot and pull lists as soon as possible to instructed office.
8. If not furnished a spot and or pull list, then all cars switched must be listed on a Form 16 and turned in at instructed office.

SPOTTING CODES

- (*) Asterisk before and after a spot number indicates preferred spots.
- SPECIAL SPOT NUMBER CODED
The last two digits of a SPINS number may convey a special meaning and are listed below:
- | | | | |
|----|------------------------------------------------------------------------|----|-----------------------------------------------------------------------------------------------------------------------------------------------------------------------------------------------------------------------------------------------------------|
| 90 | Team track spotting | 95 | Dock spotting |
| 91 | Storage track | 96 | Piggyback |
| 92 | Denotes industry will either do the switching or furnish a switch list | 97 | Auto Ramp |
| 93 | Crane spotting | 98 | Interchange to other railroads |
| 94 | Hopper dump | 99 | Open area where not possible to put up spot signs |
| | | 00 | When a car cannot be spotted according to the switch list and is left off spot, 00 will be indicated on the returned list. If car is left on a track other than designated on list, Track number & Spot where car is left will be shown in addition to 00 |

LANDMARK SYMBOL LEGEND

Sheet 1

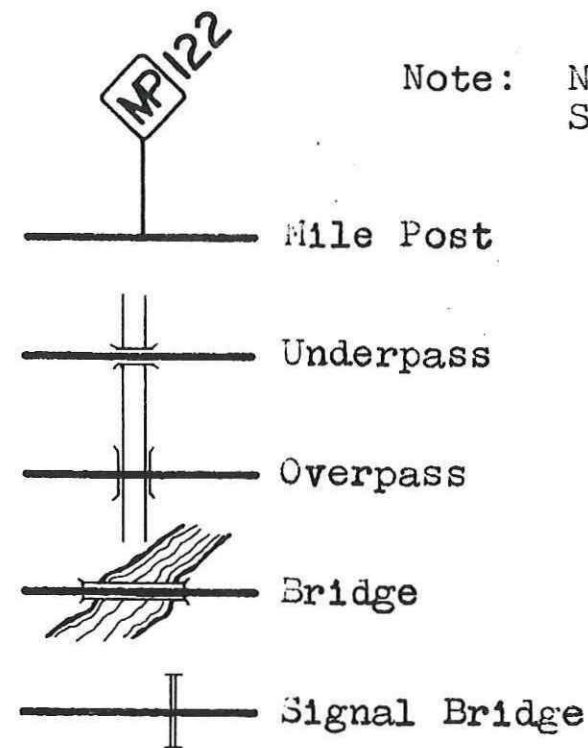

Note: Not to be used in place or instead of Special Instructions or Timetable Bulletins

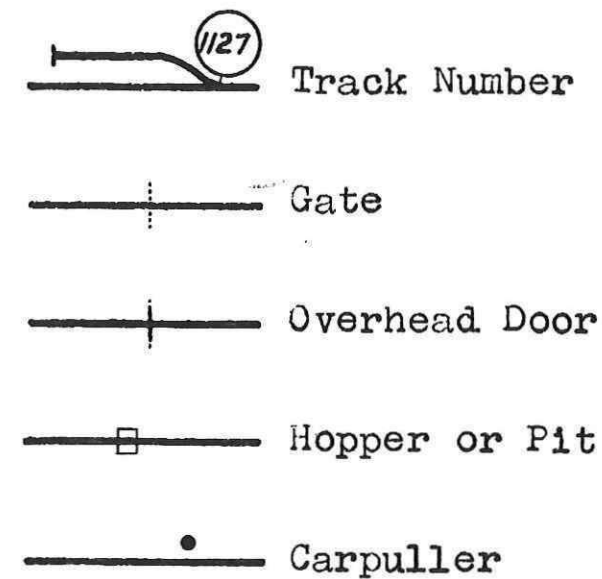

(cont'd)

LANDMARK SYMBOL LEGEND

Sheet 2

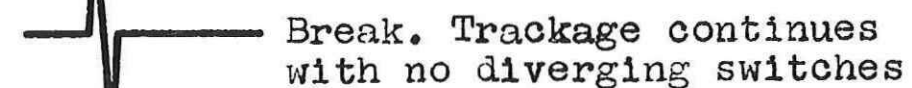
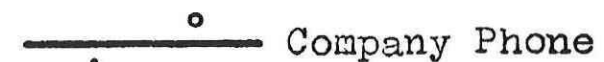
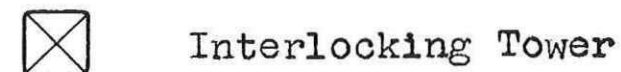
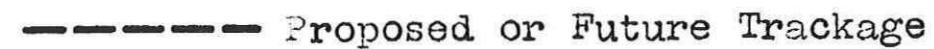
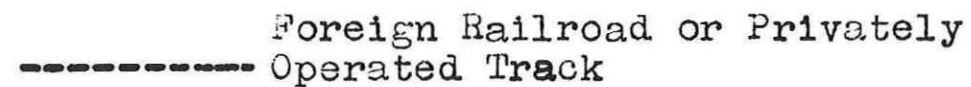
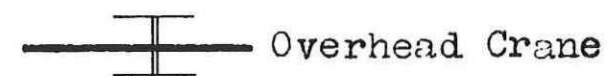
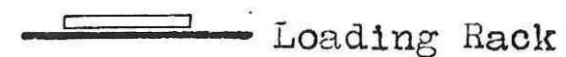
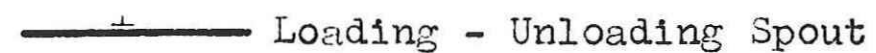

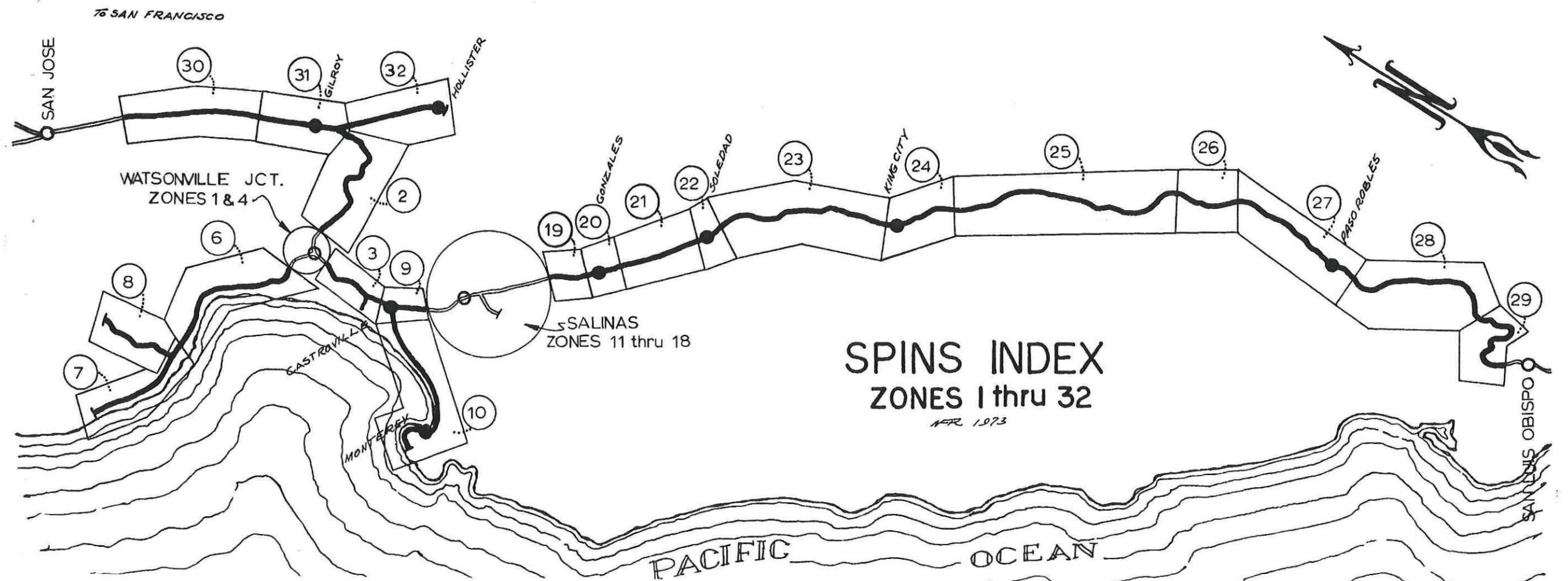

To SAN FRANCISCO

MP 99

MP 100

To LOS ANGELES

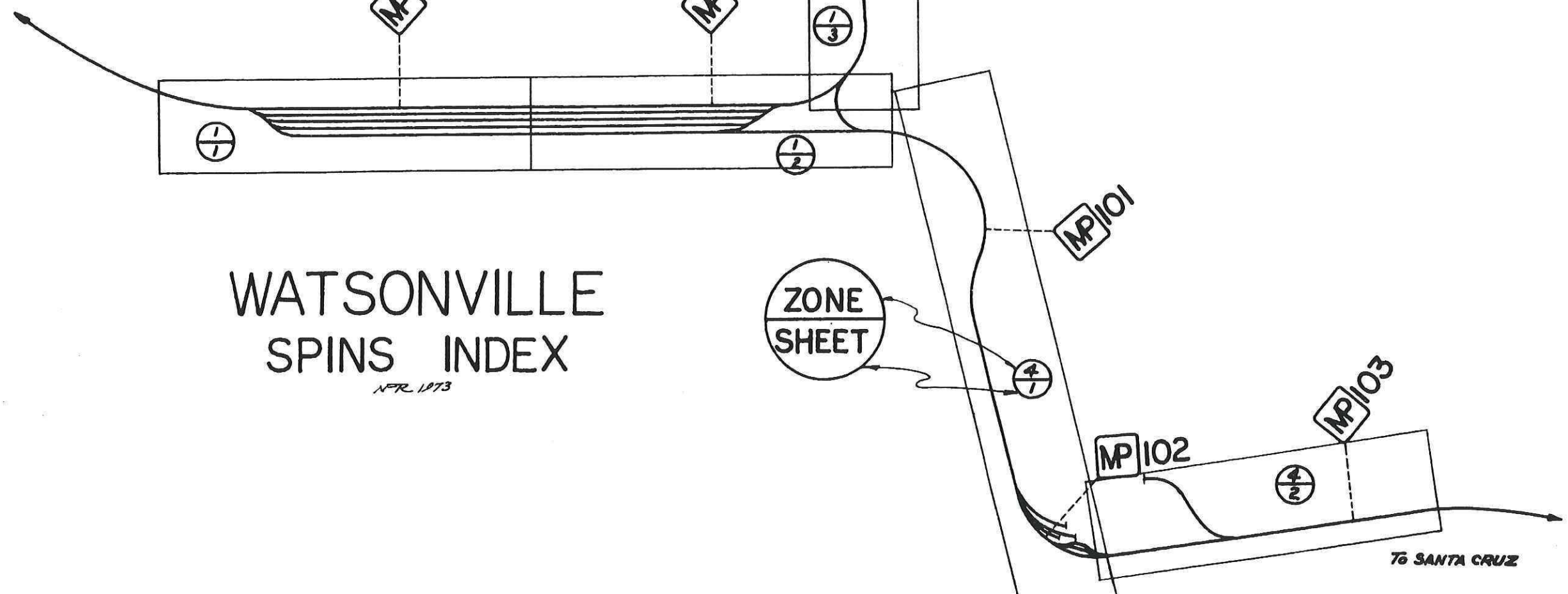

WATSONVILLE SPINS INDEX

NFR 1973

ZONE
SHEET

To SANTA CRUZ

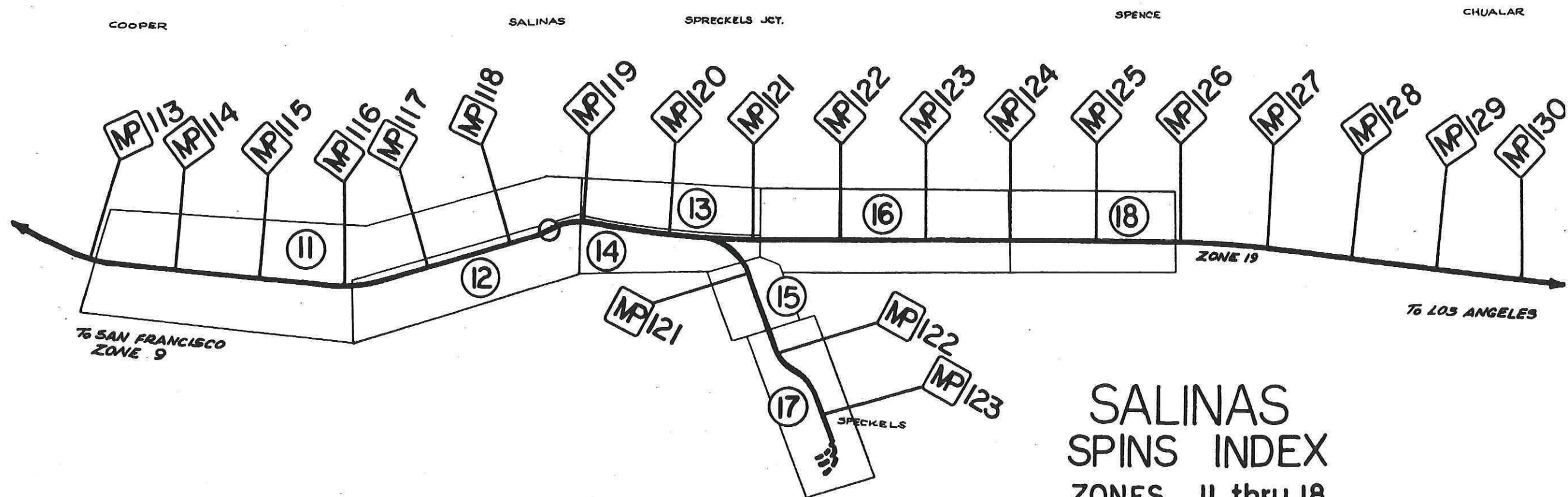

SALINAS
SPINS INDEX
ZONES 11 thru 18

NFR 1973